

Clarke®



BOLTLESS SHELVING

MODEL NO: CSR5450BP/RP/LG

PART NO: 6600524 (BLUE), 6600525 (RED), 6600526 (LIGHT GREY)

USER INSTRUCTIONS



GC0715

INTRODUCTION

Thank you for purchasing this CLARKE Boltless Shelving. Before attempting to assemble this product, please read this manual thoroughly and follow the instructions carefully. In doing so you will ensure the safety of yourself and that of others around you, and you can look forward to your purchase giving you long and satisfactory service. In the event of damage, spare parts are available from the Clarke International parts department.

UNPACKING & ASSEMBLY

When unpacking, check for damaged or missing parts. Any deficiencies found should be reported to your CLARKE dealer where the product was originally purchased. Do not dispose of damaged components or packaging with general household waste. They should be taken to a recycling centre and disposed of appropriately.

This product should include the following items:

No	Description	Quantity
A	Corner Post	8
B	Long Beam	10
C	Short Beam	10
D	Centre Beam	5
E	Shelf	5
F	Post Connector	4
G	Plastic End Cap	8

ASSEMBLY ADVICE

1. Assemble on a firm, level surface. Avoid assembly on a domestic carpet.
2. Use a cloth or softwood block to protect the surface finish of the product when using a mallet.
3. Always ensure that the tabs sit at the bottom of the keyhole slots.
4. It is recommended that the assembly should be done by two persons.
5. Follow all steps if wishing to create a single 5-shelf unit or ignore steps 6 & 7 if wishing to create two units with only 2/3 shelves.
6. It is recommended that the shelving unit be fixed to an adjacent wall.
7. If required, two free standing benches can be created instead of shelving.

ASSEMBLY

The tabs of the beams will often enter the slots fully using just firm hand pressure but if they are too tight, you may require a rubber mallet to assist. If so, always use a cloth to protect the product paint finish. Tap gently with the mallet to drive the tabs of the beams fully into the slots in the corner post. Always strike the edge close to the post.

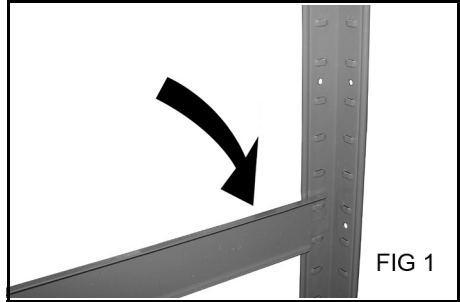

1. Decide how high you want the shelves to be, relative to the floor, noting that the bottom shelf should never be more than 150mm from the bottom of the legs. If it is wished to have the bottom shelf in a higher position, then additional beams should be positioned near the bottom of the corner posts.

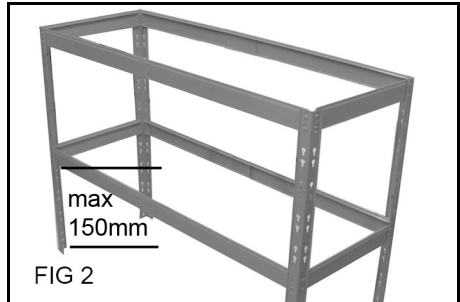

2. Use the short beams to connect two posts together as in Fig 1.

IMPORTANT: Note that the edge with the wider flange should be installed uppermost to support the shelf.

3. Repeat this again for the other end assembly, making sure that the corresponding beams are at the same height.
4. Use the long beams to connect the two end assemblies together as shown in Fig 2.
5. Connect the centre beams to the long beams by bending the flexible tabs to 90 degrees and slotting them into place as shown in Fig 3. Finally bend the tabs back 180 degrees to lock in place.

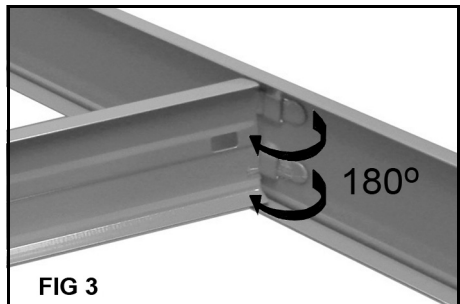

6. Fit the post connectors to the lower corner posts and add the upper posts as shown in Fig 4.
7. Assemble the upper beams in the same way as the lower beams.
8. Position the shelves on the beams.
9. Fit the plastic end caps to each corner post.

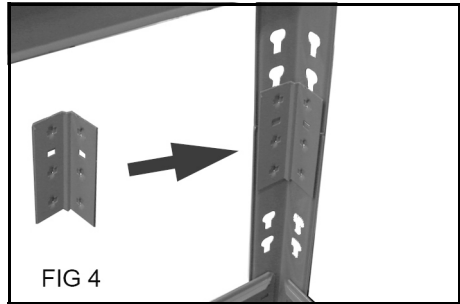

SAFETY ADVICE

- Always place heavier items on the lower shelf.
- Always distribute loads evenly across the shelves.
- The shelving unit is not recommended for outdoor use.
- Do not exceed the maximum load of 450kg per shelf.

GUARANTEE

This CLARKE product is guaranteed against faulty manufacture for a period of 12 months from the date of purchase. Please keep your receipt as proof of purchase. This guarantee is invalid if the product is found to have been abused or tampered with in any way, or not used for its intended purpose.

Faulty goods should be returned to their place of purchase, no product can be returned to us without prior permission.

This guarantee does not effect your statutory rights.

A SELECTION FROM THE VAST RANGE OF

Clarke®

QUALITY PRODUCTS

AIR COMPRESSORS

From DIY to industrial, Plus air tools, spray guns and accessories.

GENERATORS

Prime duty or emergency standby for business, home and leisure.

WOODWORKING

Saws, sanders, lathes, mortisers and dust extraction.

POWER WASHERS

Hot and cold, electric and engine driven - we have what you need

WELDERS

Mig, Arc, Tig and Spot. From DIY to auto/industrial.

METALWORKING

Drills, grinders and saws for DIY and professional use.

WATER PUMPS

Submersible, electric and engine driven for DIY, agriculture and industry.

POWER TOOLS

Angle grinders, cordless drill sets, saws and sanders.

STARTERS/CHARGERS

All sizes for car and commercial use.

CLARKE INTERNATIONAL HEMNALL STREET, EPPING, ESSEX CM16 4LG